

**MMINUTES OF THE 3<sup>RD</sup> MEETING OF BUILDING & WORKS COMMITTEE  
OF NATIONAL INSTITUTE OF TECHNOLOGY ROURKELA HELD ON 5<sup>TH</sup>  
JANUARY, 2005 AT 10.00 AM IN THE BOARD ROOM OF NIT, ROURKELA**

---

Prof. Sunil Kumar Sarangi, Director, NIT, Rourkela presided over the meeting.

**Members Present:**

- 1) Mr. S.C. Padhi, Superintendent Engineer (Civil),  
CPWD, Bhubaneswar.
- 2) Mr. D.P. Kuanhar, Executive Engineer (Elect.)  
C.P.W.D., Bhubaneswar.
- 3) Shri C.R. Nanda,  
EE/ BCD-I, Bhubaneswar.
- 4) Prof. G.K. Roy,  
Dean (PD), NIT, Rourkela
- 5) Prof. K.C. Patra,  
Professor, Civil Engg., NIT., Rourkela.
- 6) Prof. J.K. Satpathy,  
Professor, Electrical Engg., NIT., Rourkela.
- 7) Prof. P.K. Nanda,  
Professor, Electrical Engg., NIT., Rourkela
- 8) Prof. S.P. Singh,  
Asst. Professor, Civil Engg, NIT.,Rourkela
- 9) Prof. A. K. Panda,  
Visiting Professor, Civil Engg, NIT,Rourkela.
- 10) Prof. Y.K. Sahu,  
Visiting Professor, Electrical Engg.  
NIT Rourkela
- 11) Er. S.K. Upadhyay,  
Registrar & Ex-Officio Member Secretary  
Building and Works Committee.

**Members Absent:**

- 12) Dr. S. Mishra,  
Managing Director,  
SAIL, Rourkela.
- 13) Dr. G.L. Jambhulkar  
Dy. Educational Adviser (NIT),  
MHRD, Dept. of Secondary Education & Higher Education,  
Room No. 529-C, Wing, Shastri Bhawan,  
New Delhi.

**BWC: 3 (2005)-1 : Welcome to the members by the Chairman.**

Prof. S.K. Sarangi, Director, NIT., Rourkela and Chairman, Building & Works Committee welcomed the members and introduced them to the Committee.

**BWC: 3 (2005)-2 : Confirmation of the minutes of the 2<sup>nd</sup> Meeting and matters arising out of the last Building and Works Committee held at the Board Room of NIT, Rourkela on 01.09.2004 and action taken.**

The Minutes of the 2<sup>nd</sup> Meeting of the Building and Works Committee were confirmed. The Committee reviewed the action taken on various decisions of the Building and Works Committee taken in its 2<sup>nd</sup> meeting.

***Annexure - I***

**BWC: 3 (2005)-3: To discuss the proposed “Contract procedure” and recommend to BOG for approval.**

***Annexure-II***

The Committee accepted the draft procedure in principle. However, it was decided to consult CPWD procedures and in case anything important was not included in our procedure, the same should be incorporated.

**Action: Dr. K.C. Patra, Civil Engineering Department**

**BWC: 3 (2005)-4: To review the work on water supply:  
M/s Geoinformatics, Bhubaneswar were entrusted with the task of augmentation of the water supply system of the campus. Because of delay by the party (for reasons beyond their control) the contract was terminated.**

**M/s M.N. Dastur & Co. have been entrusted with the task of augmentation of the Water supply system and the water purification system vide work order dated 16.12.2004.**

**Action: Dr. A.K. Panda, Visiting Prof., Civil Engg.**

The survey and other data submitted by M/s Geoinformatics have been passed on to M/s Dastur Co. They will submit a working note on the scheme shortly. On receipt of our comments on the same, they will prepare detailed technical specifications and bill of quantities, based on which tendering action will be initiated. In order to expedite tender finalization, CPWD engineers advised to call bidders conference to freeze technical specifications after which price bids should be opened. Tender finalization is expected to be completed by end of February, 2005.

**BWC: 3 (2005)-5: To review the progress of other civil work being carried out.**  
**a) Compound wall around academic area being implemented by IDCO.**

Wall on the south side is progressing. Wall on the North side will be taken up shortly. The work has been delayed due to non-availability of bricks as claimed by IDCO. The Committee took a serious view of the delay in completion of the work and advised the Director to contact the Senior Officials of **IDCO**.

**b) Periphery road being constructed by IDCO.**

Sand and moorum filling in the base has been completed. Metalling work will be taken up shortly. The Committee took a serious view of the delay in completion of the work and advised the Director to contact the Senior Officials of **IDCO**.

**c) Renovation of Guest House and Visitors House.**

Tender under finalization.

**d) Renovation of academic buildings.**

Work in progress. It was decided that for painting works, supply of paint, preparation of surface and application of paint should be in the scope of the contractor. Accordingly, tender is to be finalized.

**e) Renovation and remodeling of Administrative block.**

Final BOQ and drawings are expected from Architect, Sri D.K. Parida of Bhubaneswar by 10.1.2005. Thereafter, tendering action will be initiated. It was decided to approve engagement of Sri Parida for the work.

**f) Chemical treatment of roofs in academic block.**

Work order has been issued and the work is in progress.

**g) Compound wall around the whole campus.**

Open tenders invited. Tender finalization expected by 15.01.2005.

**h) Improvement of plantation and Lawns & Gardens.**

The Committee expressed satisfaction over the work in progress.

**i) Provision of bath rooms in G type quarters.**

Tenders finalized. Work order to be issued after settling modality of construction.

**j) Renovation of kitchens of all halls.**

Scheme under finalization.

**k) Renovation of Hall – 6 and addition of a new floor.**

Scheme under preparation by Architect, Sri D.K. Parida of Bhubaneswar.

**BWC: 3 (2005)-6: To review the civil maintenance and minor construction on campus.**

**a) Provision of approach road to A, B & C type quarters.**

Approach to 20 nos. A & B type quarters completed. For balance quarters, tender is to be finalized.

**b) Hydro insulation.**

Completed except few quarters. For future works, circular should be issued for roof leakage complaints. Chemical treatment is to be followed for such quarters.

**c) Maintenance of doors, windows etc.**

Work is in progress.

**BWC: 3 (2005)-7: To review the position of major electrical construction.**

Substation job started. Transformers and breakers procured. Purchase order for cable placed. Work order for panel fabrication placed. Tender for underground cable in process.

**BWC: 3 (2005)-8: To review and discuss the construction of the 1<sup>st</sup> Floor of S.B.I. Building, NIT, Rourkela.**

Drawing received recently. Estimate under preparation.

**BWC: 3 (2005)-9: To review the Construction of a Kuchha Road around the campus. The management of Rourkela Steel Plant has given their consent to go ahead with the construction of the rudimentary road on RSP Land skirting NIT Campus. Since slag to be provided by R.S.P. for construction of road is not free of cost, the total cost is required to be re-estimated.**

Due to emergency and being located in sensitive area, Sri. P.K. Rout, a running contractor, has been awarded with the job on single tender basis. The work has been started on 04.01.2005. The Committee discussed the need for single tender award and appreciated the need for the deviation of standard procedure.

**BWC: 3 (2005)-10: To review the status of construction of**

- a) Homi Bhabha Hall of Residence &**
- b) Guest House extension.**

Based on open tender, pre-qualification bids invited and after short listing, enquiries issued to 3 parties on 27.12.2004. Tender opening date fixed on 27.01.2005.

**BWC: 3 (2005)-11: To discuss the proposals for following new construction.**

- a) Widening of all roads in the academic area, with provision of proper drainage facility.**

Scheme under preparation will be taken up as soon as practicable.

- b) Addition of small segments of road to the Senate Hall.**

Scheme under preparation will be taken up as soon as practicable.

- c) Renovation of Lecture Gallery Complex with addition of 4 small rooms.**

Scheme under preparation will be taken up as soon as practicable.

- d) A new Library (MHRD to be requested for a special plan grant).**

&

- e) A new Lecture Hall, Class room complex (under TEQIP project).**

A brief report has been prepared by M/s Bose Brother Architects. A detailed scheme is yet to be prepared.

It was decided to make a panel of architects by selection through open advertisement for future works.

- f) A new academic building for housing new departments and research facilities (MHRD will be requested to finance under plan grant).**

Scheme is to be prepared through an Architect and put up to MHRD.

- g) **A new students' Centre with cultural facilities, Gym and Swimming Pool. (MHRD will be requested to finance under plan grant; if unsuccessful, Institute Development fees contributed by the students over the years may be used).**

Scheme to be prepared and put up to MHRD.

- h) **A new facility for staff incorporating the Rengcol Club, Haribandhu Club and Children's park. (MHRD will be requested to finance under plan grant; if unsuccessful, Institute Development fees contributed by the students over the years may be used).**

Scheme to be prepared and put up to MHRD.

**BWC: 3 (2005)-12: To examine the proposal to convert existing two-seater rooms to single rooms in Halls – 1, 3 & 4.**

Scheme to be prepared and put up to MHRD.

**BWC: 3 (2005)-13: To recommend and personnel requirement including number, qualifications and designations for the Institute.**

Presently, the construction/ maintenance works are being looked after by 2 faculty members and one Visiting Professor each in Civil and Electrical Department. NIT has hired 4 stipendiary Engineers from Engineering Schools ( 3 Civil + 1 Electrical). In addition to this, a Civil Engineering Associates firm has been engaged which provides 3 Civil Engineers (2 retired from RSP) and one Secretary. The Committee recommends the following regular staff structure.

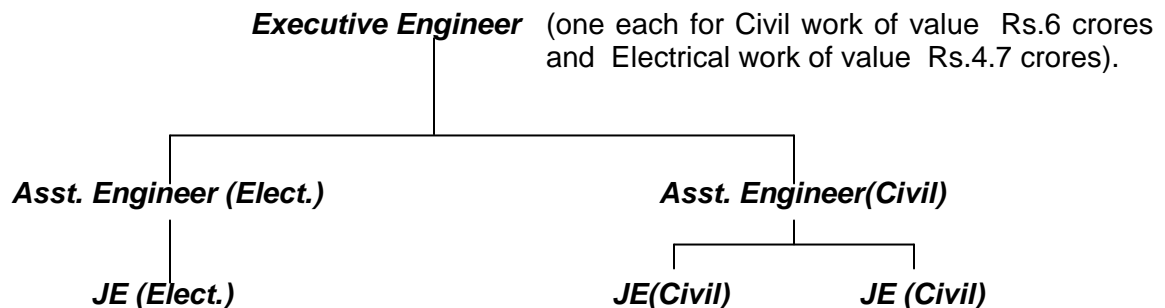

**BWC: 3 (2005)-14 : Any other item with the permission of the Chair.**

Representatives of CPWD suggested to NIT to assign them at least one job costing about Rs.1.00 crore or more to CPWD and gain experience with the agency.

The meeting ended with thanks to the Chair.

**(Dr. Sunil Kr. Sarangi)**  
**Director & Chairman**  
**BUILDING & WORKS COMMITTEE**  
**NIT., Rourkela**

**(S. K. UPADHYAY)**  
**REGISTRAR & SECRETARY**  
**BUILDING & WORKS COMMITTEE**  
**NIT., Rourkela**

**MINUTES OF THE 2<sup>ND</sup> MEETING OF BUILDING & WORKS COMMITTEE OF NATIONAL INSTITUTE OF TECHNOLOGY ROURKELA HELD ON 1<sup>ST</sup> SEPTEMBER, 2004 AT 10.00 AM IN THE BOARD ROOM OF NIT, ROURKELA**

---

Prof. Sunil Kumar Sarangi, Director, NIT, Rourkela presided over the meeting.

The following attended the meeting:

- 13) Mr. S.C. Padhi, Superintendent Engineer (Civil), CPWD, Bhubaneswar.
- 14) Mr. D.P. Kuanhar, Executive Engineer (Elect.) C.P.W.D., Bhubaneswar.
- 3) Shri B.K. Ray, Desk Officer, Government of India, MHRD, Department of Secondary & Higher Education, 435- C , Shastri Bhavan, New Delhi – 110 001.
- 15) Prof. G.K. Roy, Dean (PD), NIT, Rourkela
- 16) Prof. K.C. Patra, Professor, Civil Engg., NIT., Rourkela.
- 17) Prof. J.K. Satpathy, Professor, Electrical Engg., NIT., Rourkela.
- 18) Prof. P.K. Nanda, Professor, Electrical Engg., NIT., Rourkela
- 19) Prof. S.P. Singh, Asst. Professor, Civil Engg, NIT., Rourkela
- 20) Prof. A. K. Panda, Visiting Professor, Civil Engg, NIT, Rourkela.
- 21) Er. S.K. Upadhyay, Registrar & Ex-Officio Member Secretary Building and Works Committee.

**BWC: 2 (2004)-1 : Welcome to the members by the Chairman.**

At the outset Prof. S.K. Sarangi, Director, NIT., Rourkela and Chairman, Building & Works Committee welcomed the members and introduced them to the Committee. Thereafter the following agenda items were discussed.



**BWC: 2 (2004)-2 : Confirmation of the minutes of the 1<sup>st</sup> Meeting and matters arising out of the last Building and Works Committee held at the Board Room of NIT, Rourkela on 22.09.2003.**

Sl. No.	Item No.	Item Descriptions	Present status	Responsibility
1.	BWC:1(2003)-2	To review the ongoing construction projects	Three numbers of 'E' type quarters has been held up by the contractor due to hike in steel. It was decided that the contractor will be asked to complete the rest of work within a specified period, otherwise action will be taken as per the terms and conditions of the contract. The committee did not approve to pay escalation of price due to hike in steel price.  PC Cell is advised to complete the balance work by December, 2004.	Dr. K.K.Mishra, Prof., Civil Engg
2.	BWC:1(2003)-3	To work out a policy towards selection of Architects and Contractors and award of work contracts.	Completed	-
3.	BWC:1(2003)-4	To consider award of a contract to a reputed surveying Firm to generate a contour map for use in design of future construction projects.	Completed	-
4.	BWC:1(2003)-5	To consider the following Civil works for the Institute:  a) Construction of Compound Wall around the Academic Campus.	M/s IDCO has submitted concrete block sample for approval.  Estimation under preparation.	Dr. K.C.Patra, Prof., Civil Engg  Prof.A.K.Panda, Visiting Professor,

		<p>b) Construction of Compound Wall and perimeter road around the whole campus.</p> <p>c) Completion of Hall-6 to stop water seepage and consequent damage to the building.</p> <p>d) Renovation of Water Supply system.</p>	<p>2<sup>nd</sup> Floor to be constructed based on drawings to be supplied by Architects.</p> <p>Geo Informatics is conducting survey. Report/ Drawings expected by 30.9.2004.</p>	<p>Civil Engg.</p> <p>Prof.A.K.Panda, Visiting Professor, Civil Engg.</p>
5.	BWC:1(2003)-6	To consider renovation of Hostel dining halls, kitchens and associated facilities and award of contract on single quotation basis to an alumnus of the Institute.	Renovation of Kitchens, Dining Hall of Hall-1 is completed and renovation of other Halls would be taken up.	Prof.A.K.Panda, Visiting Professor, Civil Engg.
6.	BWC:1(2003)-7	To discuss and approve the construction of Main Gate, Jagda Gate, Back Post gate and Academic Campus Gates – Selection of architects and subsequent construction.	Main Gate completed. For Jagda Gate, tendering in process. Back Post Gate and Academic Campus Gate yet to be taken up.	

7	BWC:1(2003)-8	To discuss and approve renovation of Institute Guest House and Visitors Hall-assignment to Architect and subsequent construction.	M/s Bose Brother submitted drawings and tendering is to be done	Prof.A.K.Panda, Visiting Professor, Civil Engg.
8	BWC:1(2003)-9	To discuss and approve remodeling of Directors Deans Offices and Board Room Complex – assignment of Architect and subsequent construction.	Drawing received. Detail specifications are yet to be firmed up.	
9.	BWC:1(2003)-10	To discuss and approve a project for maintenance and painting of the Academic Building.	Estimate under preparation.	Prof.A.K.Panda, Visiting Professor, Civil Engg
10.	BWC:1(2003)-11	To discuss and approve a project for maintenance of staff quarters.	A procedure has been formulated.	
11.	BWC:1(2003)-12	To discuss and approve a plan for remodeling the lighting system in the kitchen, dining halls, common rooms and corridors of the hostels, and to provide plug points with electrical protection in the rooms of students.	Lighting system of Halls except Hall-4 and Hall-6 will be completed by 31.12.2004. Bath room doors to be changed.	Dr. J.K.Satpathy, Professor, Electrical Engg.
12.	BWC:1(2003)-13	To review the electricity supply scenario of the Institute and to work out a strategy for improving the quality of electricity power delivered to the academic area, hostels and the residential area.	Regarding Installation of Energy meter it was decided to approach E.R.C. Electricity regarding commission.	Dr. J.K.Satpathy, Professor, Electrical Engg

13.	BWC:1(2003)-14	To discuss and approve a project for providing irrigation water to the academic campus for preserving greenery during the dry season.	Completed.	
14.	BWC:1(2003)-15	To consider dismantling of a cycle shed in front of the AE & IE & CSEA departments and construction of a new one as requested by the Professor in charge of Lands and Gardens. The recommendation of the committee set up to examine the proposal is given.	Completed	